

# HAD-200-120-54

20,000 lbs. Capacity

**PALFINGER** HOOKLIFT



STANDARD FEATURES INCLUDE:

- Available with 54" hook height
- 14ft Containers
- 12ft Containers with an 18,500 loading capacity

# The PALFINGER Principle

**PALFINGER HOOKLIFT**

SANITARY EQUIPMENT CO., INC.



Corporate Office: (203) 933-9599 25 Industry Drive, West Haven, CT, 06516

MA location: (855) 373-SECI 1140 Turnpike Street, Unit 3 & 4, Stoughton, MA, 02072

Omaha Standard Inc.  
P.O. Box 5757  
Trenton, NJ 08638

HAD-200-120-54  
11.09

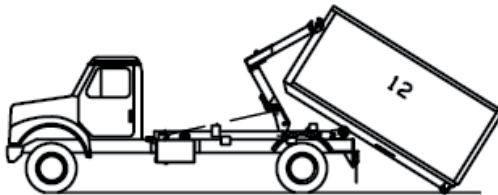
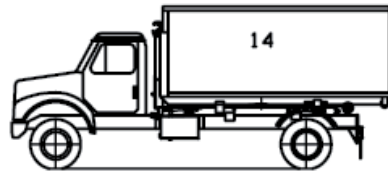
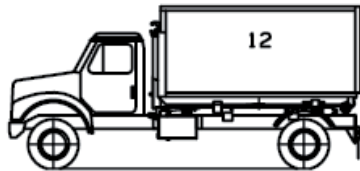

MAX. LOAD ANGLE 32 DEG

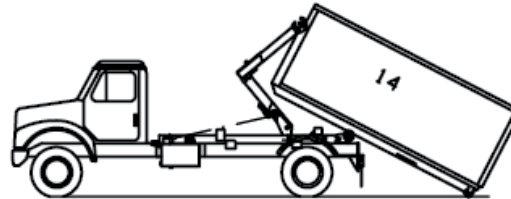

MAX. LOAD ANGLE 31 DEG

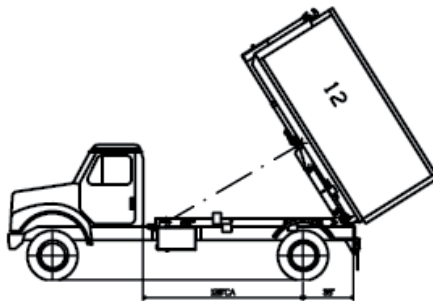

MAX. DUMPING ANGLE 58 DEG

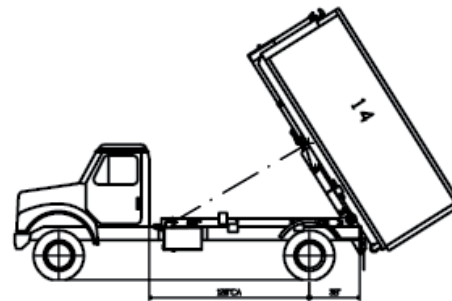

MAX. DUMPING ANGLE 58 DEG

## FEATURES:

- 20,000 LBS capacity
- High dump, "True Dump Truck" style dumping dual pivot
- Designed and manufactured in the United States
- Low pressure 2800 PSI hydraulics easily adapts to hydraulic based accessories
- Dual lift cylinders for added strength and stability
- Sliding jib to accommodate short containers and adjust the weight distribution
- Dual rear rollers side for easy container movement
- Poly fenders with full width bumper
- LED stop, turn and marker lights with factory plug-in harness
- Pintle hook mounting plate is standard
- Patented floating jib eliminates all electromechanical controls and allows the body to be slid back during the dump mode
- US manufactured pump, valve, cylinders and fittings
- All models include an A-frame drawing

## CUSTOMIZED QUICK CHANGE BODIES:

- Open top containers
- Closed storage bodies
- Salt and sand spreaders
- Tree spraying units
- Septic cleaning pumps
- Hydroseeders
- Concrete forms
- Scaffold delivery skids
- Recycling containers
- Flatbed bodies
- Dump bodies (standard & heated)
- Water tanks
- Spraying systems
- Liftgate bodies
- Cranes: skid mounted
- Bark mulch blowers
- Contractor bodies

Applications shown in the leaflet do not always correspond to the standard specifications. Design and specification are subject to change without prior notice.